



2 TONNE

CAPACITY



COMPLIES TO **AS 2359.1**

Edition : 1.0
Date: (09/25)

Instruction Manual

FORKLIFT ATTACHMENT

FLA-2T-2G

Order Code: (C195)

GENERAL INFORMATION

HAFCO Forklift Attachment effectively transforms a forklift into a mobile crane, handling awkward loads which cannot be safely handled by a conventional forklift with great efficiency. It has excellent strength : weight ratios. The Forklift Attachment is supplied complete with safety hook, shackle and safety chain. The capacity is rated at 2000kgs when position on the tynes 600mm from the mast

This attachment conforms to Australian Standard AS2359.1

CONDITIONS OF USE

Capacity

When using a Forklift Attachment it is possible to apply loads to a forklift which exceed the rated capacity of the forklift. This can result in the safety of a forklift being compromised and can cause serious accidents.

When ever an attachment is used it is important to re-calculate the safe working load limit. This varies when the attachment is placed in different positions along the tynes. The load chart of the forklift should be checked to see the values.

The Australian standards AS2359.1 dictate capacity reductions for forklifts used with suspended loads.

1. When a suspended load is carried (i.e. a attachment is used) the rated capacity calculated for the forklift must be reduced by 20%.
2. When two forklifts carry the same load, the load applied to each truck shall not exceed 75% of that truck's capacity

The operator must know how to read load capacity data plates. Load capacity data plates detail the load each forklift can safely lift at different mast orientations, or when fitted with an attachment.

Method of Attachment

Check to insure that the tynes are suitable and are set to the correct width. The tynes must be centered so that the hook is in the centerline of the forklift

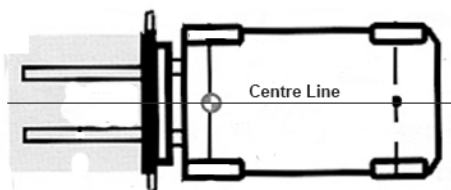

Fig.1

When using the attachment, the tynes should be horizontal to the ground and must not be tilted forward during the lift.

The forklift should be subject to the tests and inspections required under AS2359.2 before being used.

When using the attachment, if lifting accessories, such as shackles, hooks slings and chains are to be used they must be inspected by a competent person before they are used. The driver of the forklift must be licensed and needs to be experienced in perform the task of selecting the correct lifting equipment and the method in which the item is lifted.

Safety Chain

Once the attachment has been installed, secure the attachment with the safety chain so that it cannot move out from the mask by placing the safety chain around a strong point of the mask or the carriage in such a way that the attachment cannot slip off the end of the tynes.

Note! The attachment must never be used without the safety chain being attached securely to the carriage or the mast as in Fig.2

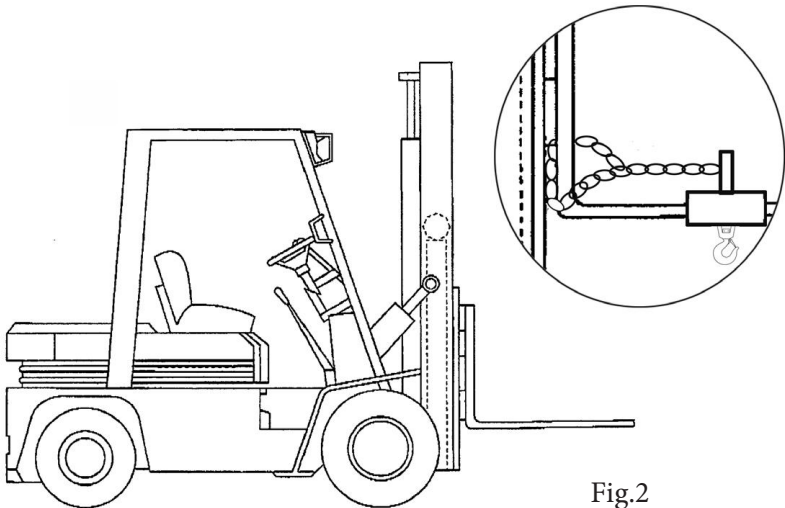

Fig.2

OPERATING AND SAFETY PROCEDURES

following is to be observed by the operator when handling loads to ensure while using this equipment any hazards identified are eliminated or controlled— See Below

1. Forklift Operation

The forklift operator must be the holder of a forklift license that covers both the Forklift and the attachment being operated. The operator using the equipment, must be trained in the safe use of the attachment and in the use of slings and chains used with the attachment.

Pre-checks in accordance with AS 2359.2 Clause 3.1 and 6.4 must be performed prior to the use of the Forklift and corrective action taken where applicable;

- a. The Forklift and the Attachment capacities recorded on the nameplates and markings must be read and understood.
- b. Check should be made on the condition of the lift and tilt system on the Forklift
- c. Tyres should be checked for wear and pressure if applicable. The forklift fluid levels in the battery cell, engine, brakes, coolant and transmission should be checked
- d. All steering and brake controls should be checked and all warning devices and lights checked to make sure they are operational
- e. The attachment must be checked that it is securely attached to the forklift with the safety chain as per Fig 2, by the operator

2. Lifting The load

The operator must know the capacity of the forklift and must not exceed it. Check the marked weight of an object, or use a weight gauge or scale to weigh the load. Do not pick up a load if you do not know its mass.

Before lifting check that the load may be handled safely with the attachment by seeking confirmation from a responsible person, that has been provided with all the information necessary, to ensure that all risks are eliminated or controlled.

- a. Do not exceed the rated capacity of the Forklift to handle the load after calculating a 20% reduction due to the attachment being added.
- b. The Forklift should be used on a hard level surface and have the enough clear space area for the lift to be attempted safely
- c. Where there may be passing traffic, warning signs or barriers must be displayed to prevent any sharing of the work area whilst lifting.
- d. When the load is elevated, move slowly and cautiously, transporting the load with the attachment as low to the ground as practicable. Speed must be kept to under 10kph
- e. The mast, if adjustable must be set vertical or tilted back, with the tynes parallel to the ground. Never drag the load horizontally along the ground, or allow the load to swing.

- g. The operator must stay with the controls of the Forklift at all times, keeping hands and feet clear of controls not being used.
- h. The operator should lift the attachment without the load to the required working height to confirm that all the systems are functioning correctly, before the load is lifted.
- i. If the load obstructs your view while traveling up an incline, get another worker to guide you from a safe position. Ensure all other people are in full view at all times. If you lose sight of them, stop immediately.
- j. Drive in reverse if a bulky load obscures your forward view. However, the load must lead when traveling up inclines. Use another worker, safely positioned, as a spotter in this instance.

MAINTENANCE

The attachment must be subject to regular maintenance to insure that it is kept in safe working order to reduce the chance of possible hazards arising. The following scheduled should be carried out.

- 1. The attachment should be cleaned after being used and stored in a safe dry place free from dirt, rubbish and possible damage.
- 2. Regular inspections by a competent person to check for excessive wear of the load bearing areas such as the hook, shackle and any other stress areas. If the attachment is damaged or displays excessive wear, a load tests should be carried out by an authorized authority and a "Certificate of Test and Examination" obtained.
- 3. The name plate should be checked to make sure the information on the plate is legible. If the nameplate is missing, a load tests should be carried out by an authorized authority who will provide a name plate that will be attached to the attachment. If the name plate has been removed or damaged and cannot be read the attachment should be removed from service until the problem has been rectified and a new plate attached to the attachment.

NAME PLATE

The name plate is also the compliance plate and must be attached to the forklift attachment. It must be legible and must be able to be read clearly

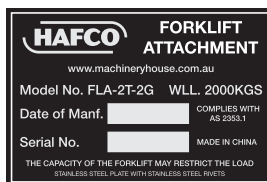

RISK ASSESSMENT

1. Attachment Condition.

The attachment must be maintained for a proper working condition. Never operate an attachment that has damaged or worn parts. Scheduled routine maintenance should be performed on a scheduled basis. Check the frame, chain, shackle and hook for cracks or damage. Replace if necessary.

2. Safe Operation.

Use extreme care when handling long, high, or wide loads. Do not lift loosely stacked loads. Always balance heavy loads and move them as close to the ground as possible for maximum stability. Only operate the forklift with the attachment if you are sure that you can control and stop it safely when it is moving. When lifting or lowering, the load, it should be moved slowly and steadily to avoid jerking. The load must be directly under the hook before lifting to eliminate the load swinging. Always use the correct, lifting slings and chains.

3. Crushing Hazard.

Never place any part of your body under the attachment, or under a lifted load. Serious injury can occur. Get assistance when installing the attachment, as it is heavy. Lifting heavy weights can cause serious injury.

4. Work area hazards.

Pay attention to other persons in the area and know what is going on around the area to ensure unintended accidents.

5. Warning Labels.

Take note of any warning labels on the forklift and attachment and do not remove them.

6. Material Hazard.

Do not lift objects that are not secured properly. If they fall off serious injury can occur.

7. Other Hazards.

Never allow children to play on the forklift or attachment, and never carry passengers!

8. Call for help.

If at any time you experience difficulties, stop and call your supervisor or your nearest service department for help.

The HAFCO Forklift Attachment Conforms to Australian standard AS2359.1

DISTRIBUTED BY	
Australian Distributor	New Zealand Distributor
Hare & Forbes Machineryhouse Sydney - Melbourne Adelaide - Brisbane - Perth	Machineryhouse Auckland Christchurch
Ph: 1300 202 200	Ph: 0800 142 326
www.machineryhouse.com.au	www.machineryhouse.co.nz
Made in China	

Product Warranty

IMPORTANT INFORMATION

1 Year Limited Warranty

HAFCO offers a one year limited warranty on this product.

HAFCO warrants to the original retail consumer and purchaser that this product will be free from defects in materials and workmanship for one year from the date the product was purchased ('the warranty period').

HAFCO will rectify any defect in materials or workmanship appearing within the warranty period by repairing or replacing the product. HAFCO will offer a refund of the purchase price if the product cannot be readily and quickly repaired or replaced. HAFCO reserves the right to determine whether the product contains any defects in materials or workmanship covered by this warranty.

The benefits offered by this warranty are in addition to your rights and remedies that may apply in law. Our goods come with guarantees that cannot be excluded under the Australian Consumer Law. You are entitled to a replacement or refund for a major failure and for compensation for any other reasonable foreseeable loss or damage. You are also entitled to have the goods repaired or replaced if the goods fail to be of acceptable quality and the failure does not amount to a major failure.

How to make a warranty claim

To make a claim under this warranty, the product or part must be returned for examination to an authorised service centre nominated by Hare and Forbes Machineryhouse together with proof of purchase such as the dated sales receipt and an explanation of the problem to be rectified.

Any costs incurred in making a claim under this warranty or returning the product to an authorised service centre is to be borne by the person making the claim unless otherwise agreed by Hare and Forbes Machineryhouse. If Hare and Forbes Machineryhouse determines the product contains a defect in materials or workmanship that is covered by this warranty then Hare and Forbes Machineryhouse will bear the cost of returning the repaired product or replacement product to the person making the claim. If We determines the product does not contain a defect in materials or workmanship covered by this warranty then the cost of returning the product will be at the expense of the person making the claim.

Exclusions

This warranty does not apply to any defect caused by, or associated with misuse, abuse, lack of maintenance, negligence or accidents, repairs or alterations.



ENVIRONMENT PROTECTION

Recycle unwanted materials instead of disposing of them as waste. All tools, accessories and packaging should be sorted, taken to a recycling centre and disposed of in a manner which is compatible with the environment. When the product becomes completely unserviceable and requires disposal, drain any fluids (if applicable) into approved containers and dispose of the product and fluids according to local regulations.

Imported by

HARE & FORBES
MACHINERYHOUSE

Australian Distributor

Hare & Forbes
Machineryhouse
Sydney - Melbourne
Adelaide - Brisbane - Perth

Ph: 1300 202 200
www.machineryhouse.com.au

MACHINERYHOUSE

New Zealand Distributor

Machineryhouse
Auckland
Christchurch

Ph: 0800 142 326
www.machineryhouse.co.nz